

Hybrid Stepper Motor

57HN41-001A

High efficiency



Customized solutions on request.

Electrical Specifications

Model	Step Angle	Rated Voltage	Current	Resistance	Inductance	Holding Torque	Insulation Class
	°	VDC	A	Ω	mH	mNm	
57HN41-001A	1.8	2.1	4.2	0.5	1.2	980.7	B

Mechanical Dimensions

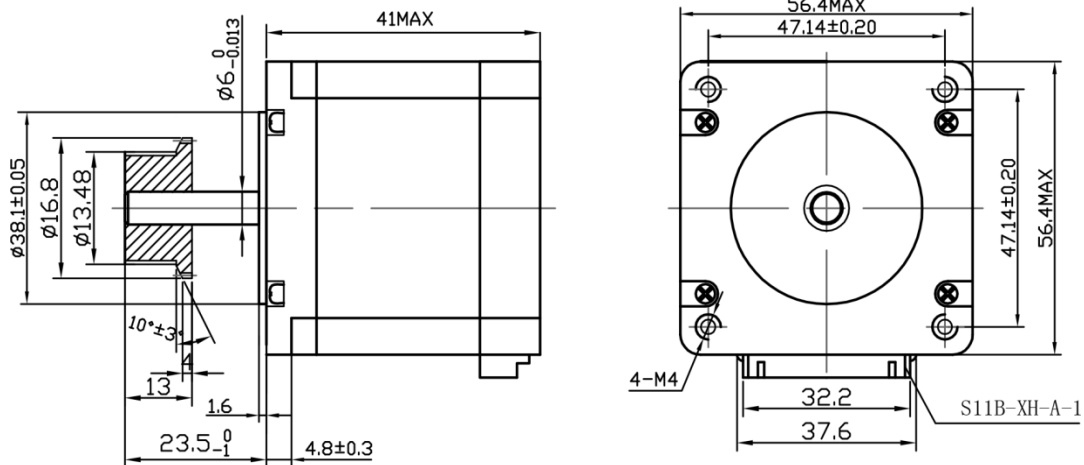

Wiring Diagram

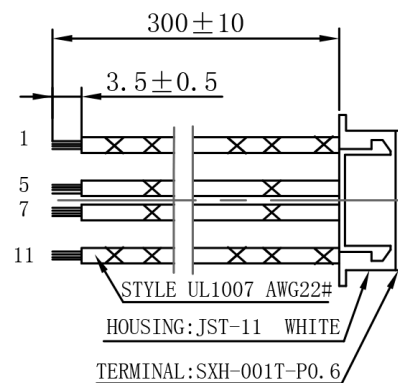
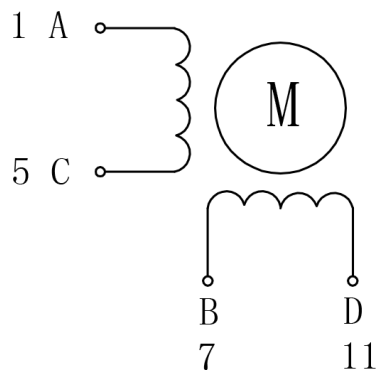

Hybrid Stepper Motor

Pulse-Torque Characteristics

57HN41-001A 4subdivision 24VDC 3A

