

Hybrid Stepper Motor

57HN46-005A

High efficiency



Customized solutions on request.

Electrical Specifications

Model	Step Angle	Rated Voltage	Current	Resistance	Inductance	Holding Torque	Insulation Class
	°	VDC	A	Ω	mH	mNm	
57HN46-005A	1.8	2.3	4.2	0.55	1.5	1040.0	B

Mechanical Dimensions

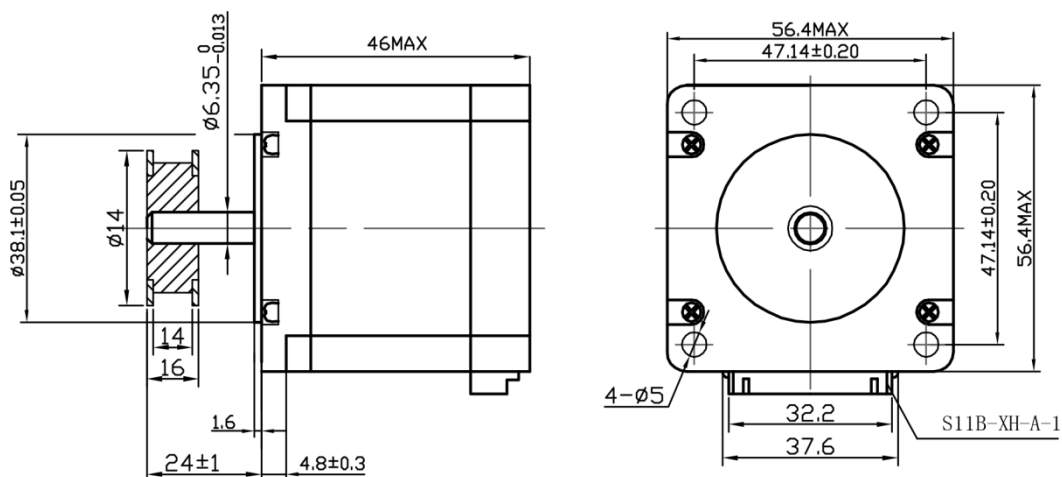

Wiring Diagram

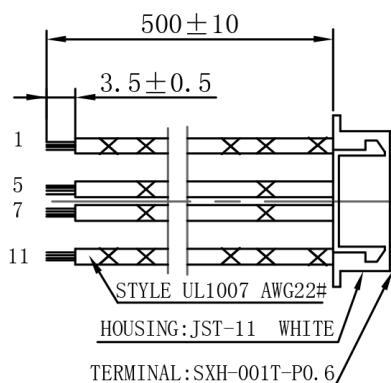
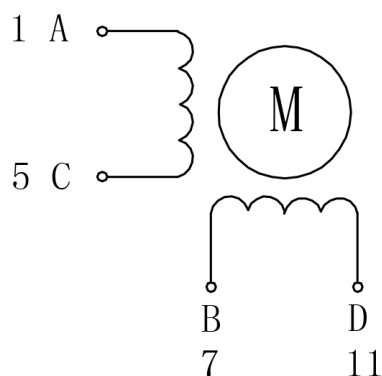

Hybrid Stepper Motor

Pulse-Torque Characteristics

57HN46-005A 4subdivision 24VDC 3A

