

# Hybrid Stepper Motor

## 57HN51-003A

High efficiency



Customized solutions on request.

### Electrical Specifications

Model	Step Angle	Rated Voltage	Current	Resistance	Inductance	Holding Torque	Insulation Class
	°	VDC	A	$\Omega$	mH	mNm	
57HN51-003A	1.8	2.7	3.0	0.9	1.8	980.7	B

### Mechanical Dimensions

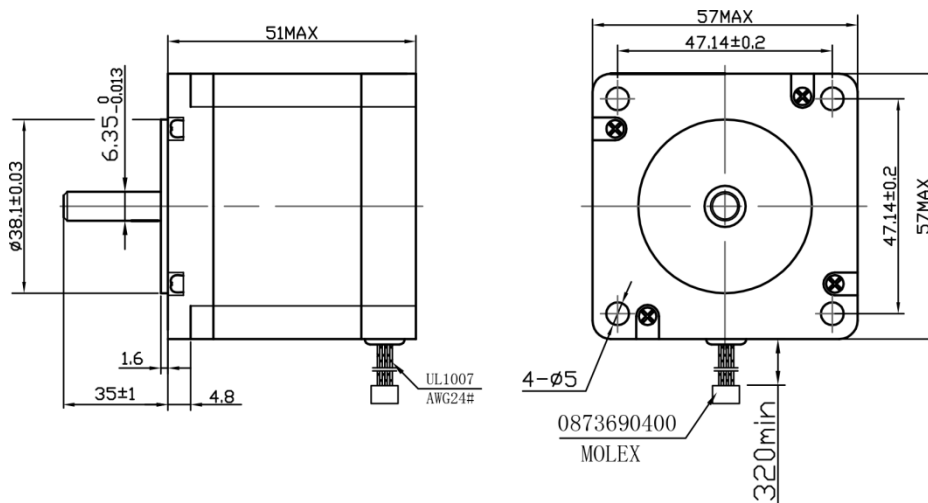

### Wiring Diagram

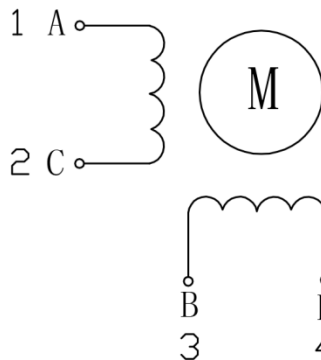

# Hybrid Stepper Motor

## Pulse-Torque Characteristics

57HN51-003A 2subdivision 24VDC 3A

