

2 Phase Hybrid Stepping Motor Driver

SD-2H086MB Series

Descriptions

086 MB type subdivision type two phase hybrid stepping motor drive, and is HETAI motor and electric APPLIANCE CO., LTD by ourselves. It is suitable for power voltage 24 V ~ 80 V, current is less than 4.0 A.

the 086MB motor driver and 42-86 mm diameter of two phase hybrid stepping motor could apply to some mechanical equipment. The driver adopted PID control of the current technology, the motor torque fluctuation, low speed running smoothly, almost no vibration and noise. High speed and torque is much higher than the other two phase drivers, higher precision. Widely used in carving machines, CNC machine, packaging machinery, and other resolution to demand higher equipment.



Features

Advanced ac servo drive current loop subdivided control technology (PID)

The motor torque is 40% than usual control ways, no lose step number (the start-up speed reach up to 300 ~ 420 r/min), the maximum speed is 3500 r/min.

The different current adopts to different mechanical transmissions and the different subsection to the output torque no influence.

The automatic half current mode reduces the driver temperature.

Protecting function: overvoltage protection, low-voltage protection, overcurrent protection and so on.

In low speed high accuracy, no noise, few fever.

Mechanical Dimensions

Electrical Parameters (Tj=25 degree Celsius)

Input voltage range	24 V - 80 VDC type: 68 VDC
Output current range	1.82 A ~ 8.28 A (peak value) resolution: 0.91 A
Driver type	PID control of the current
Insulation resistance	>500 M
Class insulation	500 V/Minute
Weight	about 850 g

Ambient requirement

Cooling	Cooling Self cool
Environment	Keep away from oil, dust, and acid gas
Temperature	0 ~ +50 degrees Celsius
Humidity	<80% RH
Vibration	5.7 m/s ² Max.
Storage temp.	-20 ~ +125 degrees Celsius

Application Notice:

To avoid use in the oil contamination, dust and corrosive gas environment

To lay it in a place with good ventilation

Please note the connection with right power (+ and -) to avoid broken the driver

Please test it when confirm the connection is right

Function description

Switch Choice: ("ON=0, OFF=1")

Current table

Output current		SW1	SW2	SW3
Average value	Peak value			
1.29A	1.82A	OFF	OFF	OFF
1.93A	2.73A	ON	OFF	OFF
2.57A	3.63A	OFF	ON	OFF
3.29A	4.65A	ON	ON	OFF

2 Phase Hybrid Stepping Motor Driver

3.93A	5.56A	OFF	OFF	ON
4.57A	6.46A	ON	OFF	ON
5.21A	7.37A	OFF	ON	ON
5.86A	8.28A	ON	ON	ON

Full current or half current choice: SW4: 0=Full current; 1=half current

When the pulse less than 0.5Hz or no pulse, the driver turn into the half current mode automatically, others the current is full current mode.

Pulse/rev Table(example 1.8° stepping motor)

Pulse/Rev	SW5	SW6	SW7	SW8
400	ON	ON	ON	ON
500	OFF	ON	ON	ON
600	ON	OFF	ON	ON
800	OFF	OFF	ON	ON
1000	ON	ON	OFF	ON
1200	OFF	ON	OFF	ON
1600	ON	OFF	OFF	ON
2000	OFF	OFF	OFF	ON
2400	ON	ON	ON	OFF
3200	OFF	ON	ON	OFF
4000	ON	OFF	ON	OFF
5000	OFF	OFF	ON	OFF
6000	ON	ON	OFF	OFF
6400	OFF	ON	OFF	OFF
8000	ON	OFF	OFF	OFF
10000	OFF	OFF	OFF	OFF

Notice: when recharge the current state or the sub ride state; the users should be powered off, than the users are re-up power.

Adapter motor: 57BYG / 60BYG / 85BYG / 86BYG (HT-motor)

Power Port DC+ DC

DC power is range from 24VDC to 80VDC. In usually, when adopt the linear power supply, the users make the ripple wave after the commutating and filtering circuitry less than 80V, keep it from breaking the motor driver. The output current of the linear power is 60% greater than the setting the rated current. When adopt the switching power supply, the customers select the rated current to match to the motor phase current. Generally, the higher power voltage, the higher the output torque; but the motor is easy to lose steps, vibration and fever.so the users choose the appropriate voltage in according to the practical mechanical condition. In addition, the high input voltage make the driver power voltage base high, when the motor braking, it is easy to take the alarm.so when the users use the big inertia motor, we don't recommend the power voltage is 80VDC.And by the experiment, the better input power voltage is 50V~70VDC.

Note: DC+ port is input power positive terminal; DC- port is input power negative terminal. The worry connection makes the driver breakdown.

Control ports explain:

1. the definition of control signals

PLS: step pulse signal is input side or the positive pulse signal input positive terminal

PLS: the negative input of the negative input of the pulse signal

DIR: stepping direction signal input to the positive terminal

DIR: Stepper direction signal negative input side

The ENA +: offline reset signal input positive terminal

The ENA -: offline enable reset signal to the negative input

Offline enable signal is active, reset the drive failure to prohibit any valid pulse, the output power of the drive components are shut down, the rotor could be moved by the outside forces.

Notice:

VCC = 5V, R short;

VCC value of 12V, R 1K greater than 1/8Wresistor;

VCC value of 24V, R 2K, than 1/8Wresistor;

R must be connected to the controller output terminals.

2 Phase Hybrid Stepping Motor Driver

2. Motor translate power

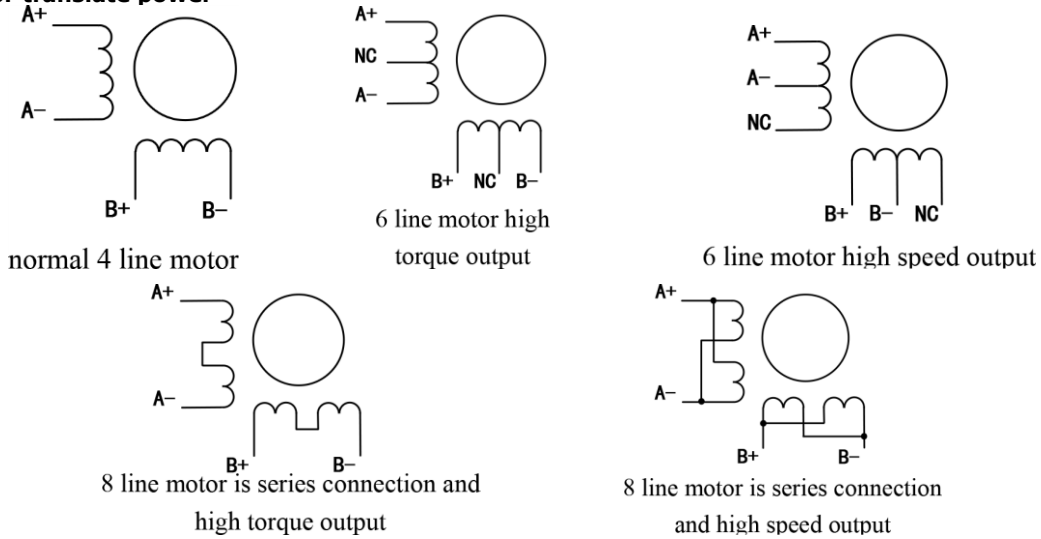

Notice: according to the five connecting ways above drawing, should set the current, in theory the higher current, the higher torque. But for reason that the motor avoid to lose the steps and rise high temperature in high speed, general in this mode of the high speed output set the output current 1.4 more than the motor rated phase current, in this mode of the high torque output set the output current is the motor rated phase current 70%. in actual, the setting phase current state is that the motor driver temperature inside 80 degree in working.

3. control signals are connected

PC control signal be high, also be low effective. When active high, the negative side of all control signals together as a signal to active low, positive side of all control signals together as a signal common. Open-collector, PNP output and differential signal output, for example, the interface circuit diagram is as follows

Controller NPN output (anode meet method)

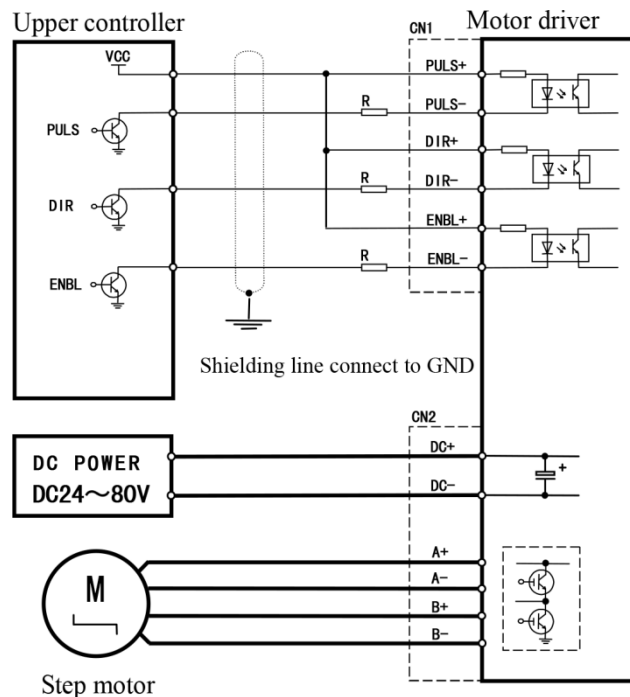

Notice:

- VCC = 5V, R short
- VCC value of 12 V, R 1K greater than 1/8 W resistor
- VCC value of 24V, R 2K, than 1/8 W resistor
- The power line and the motor line diameter is more than 1 mm²

2 Phase Hybrid Stepping Motor Driver

Controller PNP output (common cathode connection)

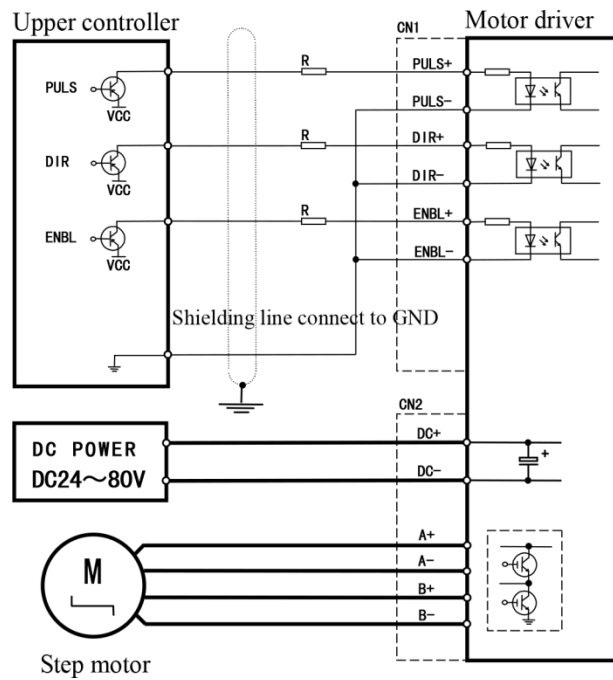

Notice:

- VCC = 5 V, R short
- VCC value of 12 V, R 1K greater than 1/8 W resistor
- VCC value of 24 V, R 2K, than 1/8 W resistor
- The power line and the motor line diameter is more than 1 mm²

Controller differential signal output

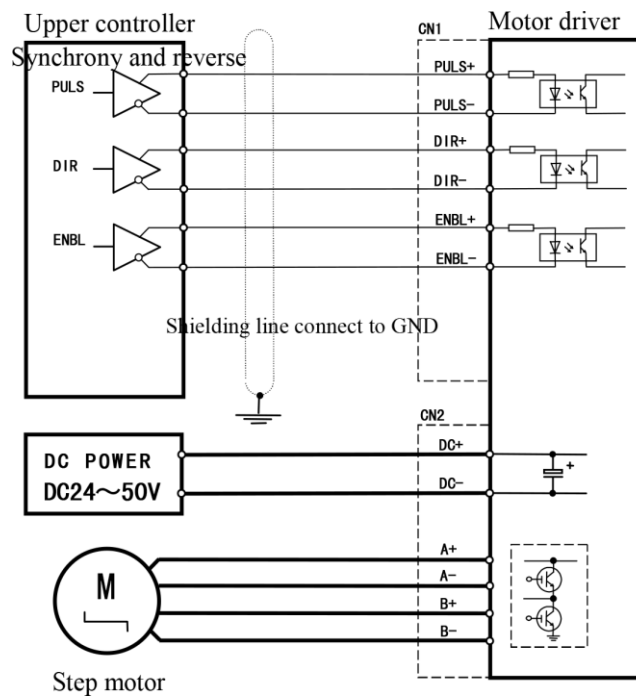

Notice:

- VCC = 5 V, R short;
- VCC value of 12 V, R 1K greater than 1/8 W resistor;
- VCC value of 24 V, R 2K, than 1/8 W resistor;
- The power line and the motor line diameter is more than 1 mm²

2 Phase Hybrid Stepping Motor Driver

Controller differential signal output

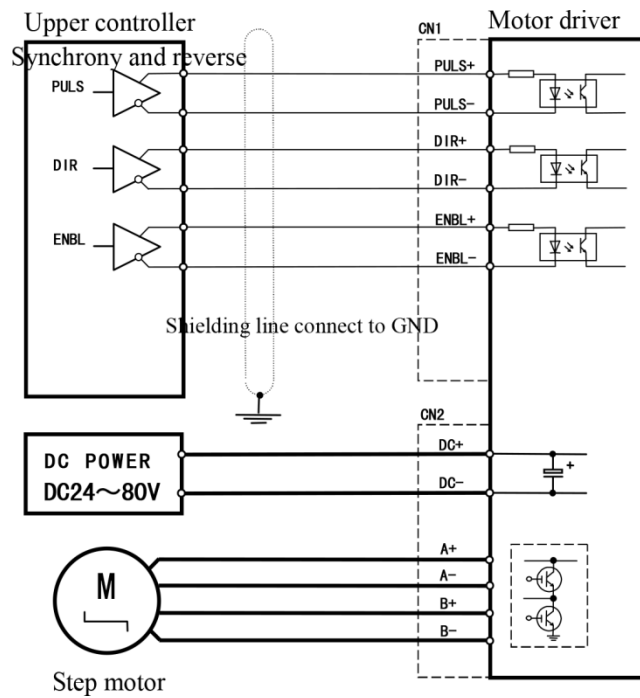

Notice:

- VCC = 5 V, R short;
- VCC value of 12 V, R 1K greater than 1/8 W resistor;
- VCC value of 24 V, R 2K, than 1/8 W resistor;
- The power line and the motor line diameter is more than 1 mm²

Installation Size

